

## Reliable. Productive. Cost effective.

### RGG Cleaning Unit

For cleaning of clamping devices and for automating machine tools

#### Field of Application

Every machine with conventional tool mountings and compressed air or coolant supply by the spindle

#### Advantages – Your benefit

**Low-price module** for flexible automation in your machine

**Fast, automatic cleaning** for a maximum machine utilization

**Idle times** reduced on a minimum

**Increased safety** for machine operator



Sizes  
Quantity: 1



Weight  
0.1 kg



## Functional Description

The cleaning unit can be used in any machine which provides compressed air or lubricating coolants supply via the toolholder taper.

Cleanliness made simple – a total of six nozzles on the ballhead blow out a powerful jet of air or coolant, which is

forced from the toolholder taper into the shaft of the cleaning unit via a bore.

The head can also rotate with the machine tool spindle when it moves, and can reach all corners of the working area.

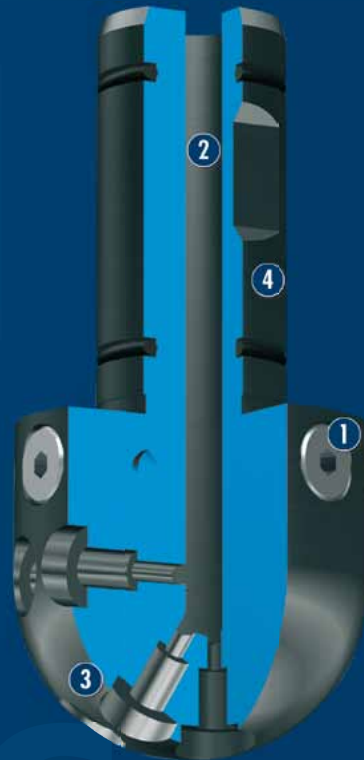

43  
78

RGG

① **Locking screws and restrictor inserts**  
for changing the cleaning jet

② **Center bore**  
for introduction of cleaning medium

③ **Outlet openings**  
for producing cleaning jets

④ **Clamping diameter**  
for mounting in any toolholding system

CAD data, operating manuals and other current product documents are available at [www.schunk.com](http://www.schunk.com)

## General Notes about the Series

**Spindle interface material:** Aluminum alloy

**Actuation:** hydraulically with machine coolant (filtered, max. particle size of 30 µm) or pneumatically with filtered compressed air in accordance with DIN ISO 8573-1: 7 4 4.

**Warranty:** 24 months (details, general terms and conditions and operating manuals can be downloaded at [www.schunk.com](http://www.schunk.com))

**Scope of delivery:** Locking screws, set-screws, assembly and operating manual



## Application example

Handling of gears in a milling center

❶ GSW-V Vacuum Gripper

❷ GSW-M Magnetic Gripper

❸ Gripper with shaft diameter GSW-B and PGN-plus

❹ Gripper with shaft diameter GSW-B and PZN-plus

❺ RGG Cleaning Unit

❻ RSS Radio Sensor System

## SCHUNK offers more ...

The following components make the product RGG even more productive – the suitable addition for the highest functionality, flexibility, reliability, and controlled production.



Vacuum Gripper



Mechanic Gripper



Toolholder



Magnetic Gripper

① Further information regarding the products can be found on the following product pages or at [www.schunk.com](http://www.schunk.com). Please contact us for further information: SCHUNK technical hotline +49-7133-103-2696

## Options and special Information

Please note that applications under extreme conditions (e.g. coolant, casting or abrasive dust) will reduce the service lifetime of this product considerably.

Please note that the product is not suitable for heat shrinking toolholders.



## Technical data

Description		RGG 20
ID		0308590
Weight	[kg]	0.1
min. / max. ambient temperature	[°C]	-10/90
max. admissible speed	[1/min]	100
max. operating pressure	[bar]	80

Main view

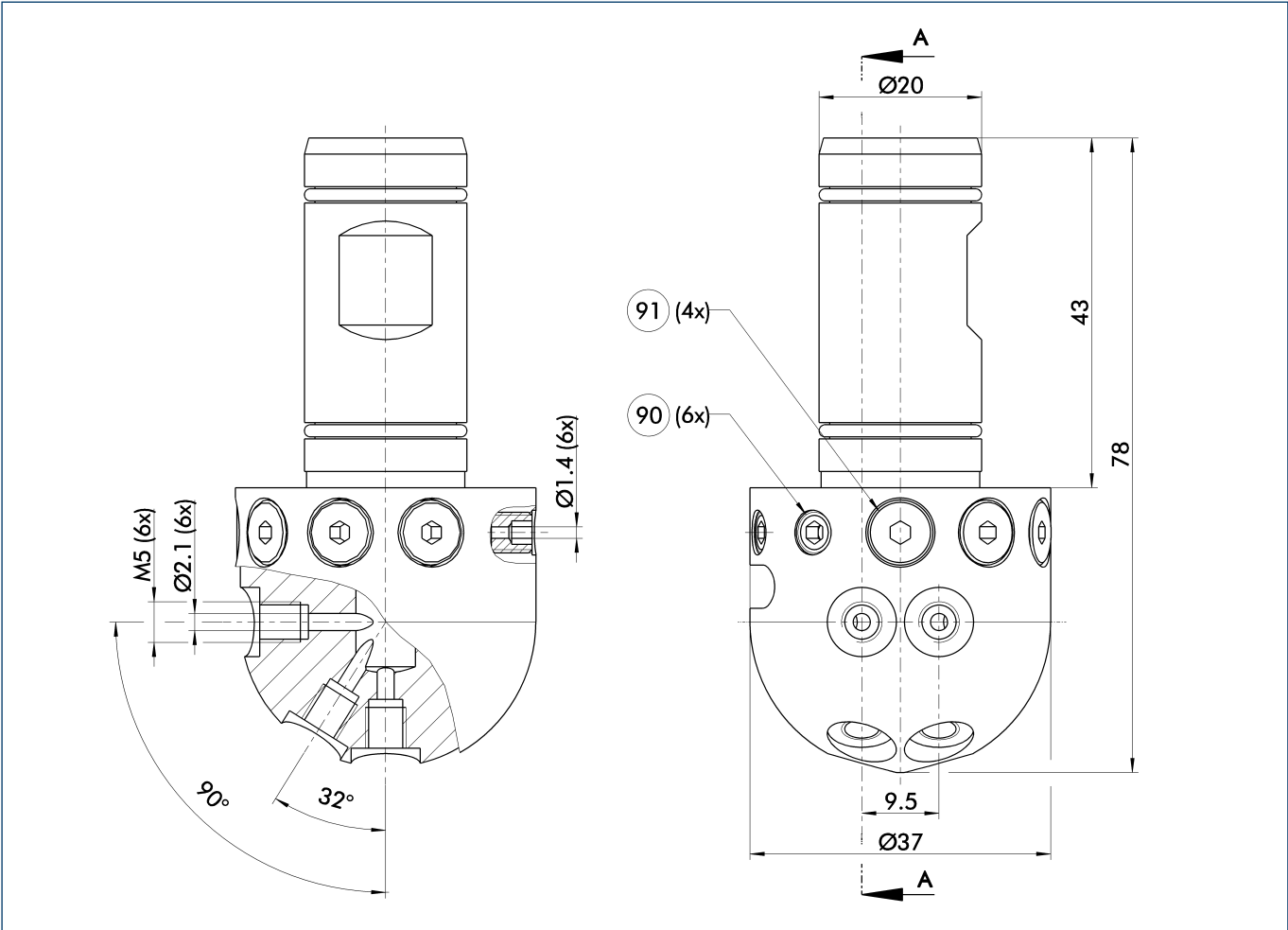

For reducing the jet of the nozzles, the set-screws with nozzle bores can be used. Unused nozzles can be closed with the locking screws.

- 90 Set-screws with throttling port
- 91 Locking screws